

# ultraframe

## Uzone<sup>®</sup> *elevation*



It is Ultraframe's policy to continually seek to improve its products, processes and services, and we reserve the right to change specifications without prior notice. Ultraframe is a trading name of Ultraframe (UK)

# ultraframe

[www.ultraframe.com](http://www.ultraframe.com)

Ultraframe (UK) Ltd,  
Salthill Road,  
Clitheroe,  
Lancashire. BB7 1PE

Ultraframe, Uzone, Elevation and  
ConservaFlash are registered trademarks of  
Ultraframe (UK) Ltd

UZETG001 BRGS0 0208 3000



world class conservatory systems

## Technical Guide

Version: 3.0

# Ultraframe: world class conservatory systems

For 25 years Ultraframe have continually been at the cutting edge of conservatory roof systems design and engineering.

## innovation

Our extensive design resources are focused on developing products that will keep you at the cutting edge of conservatory roof construction and provide the homeowner with greater style and value for money. All this is aimed at helping you secure more sales and helping your business to grow.

## engineering

Everything in an Ultraframe system is underpinned by the soundest of engineering principles. Nothing is compromised, no risk is taken and no corners are cut as we realise that it is the installer's reputation that is at risk as well as our own. At the time when there were no national industry standards, Ultraframe created them. First, by obtaining ISO for quality management systems and then BBA certifications for our roof products.

## business support

At Ultraframe we offer our customers the highest level of support. From technical on site assistance and our Customer First team for all phone enquiries, to dedicated regional sales teams and full marketing support.

## training

We train then we train again. Not just internal staff but installers, sales teams and surveyors too. Over 1,000 companies per year visit the School of Excellence at Clitheroe or take advantage of our two mobile units touring the country.

# features & benefits

Elevation and Elevation Plus bring a new and uniquely contemporary interpretation to the lean-to roof. Exclusive to Ultraframe these roofs are perfectly suited to the new generation of conservatory buyer who is looking for style, quality and value for money.

With clicklock technology at its heart Elevation is a dream to install as it easily clicks together to give the perfect finish, but there's more:

- Innovative contemporary design provides clear competitive advantage
- Unique clicklock technology speeds installation
- Unmatched thermal performance
- Available in two glazing options - 25 and 35mm
- Fully variable pitch (2½ degrees to 10 degrees)
- 4 colour options – White, Deeplas, Rosewood and Light Oak
- Structural firings at 2½ and 5 degrees are available in the 4 colour options (internal and external)
- Tested and approved by the BBA down to 2½ degrees
- Bespoke roof vents available (BBA approved)
- Integrated ventilation system for additional comfort
- Made to measure option available
- Ultraframe quality at a great price





# elevation in close-up

- 'Roof in a box' glazing bars at 750mm and 1000mm centres or between 500mm to 1000mm for a made to measure roof
- Thermally efficient design to meet current and anticipated regulations
- Structural firings available in 2½ and 5 degrees with the option to clip gutters on the side returns. Choice of colours to match the roof colour
- "Invertabar" glazing bars create cleaner lines and a more aesthetic look both internally and externally
- Unique specification polycarbonate in a choice of colours
- Available in White, Deeplas, Light Oak and Rosewood to match existing door and window finishes
- Suitable for timber, aluminium and PVCu frames (up to 70mm)
- Available from a nationwide network of stockists

The roof is designed to suit installations from 2½ degrees to 10 degrees. At factory set bar centres Elevation can free span up to 4000mm modular and 4800mm at 500mm centres bespoke (see table on page 14/15) before additional purlin supports are required, making the Elevation roof perfect for domestic and commercial applications.

Elevation is designed to work with Ultraframe's unique Conservafash, ensuring perfect watertight flashing every time.

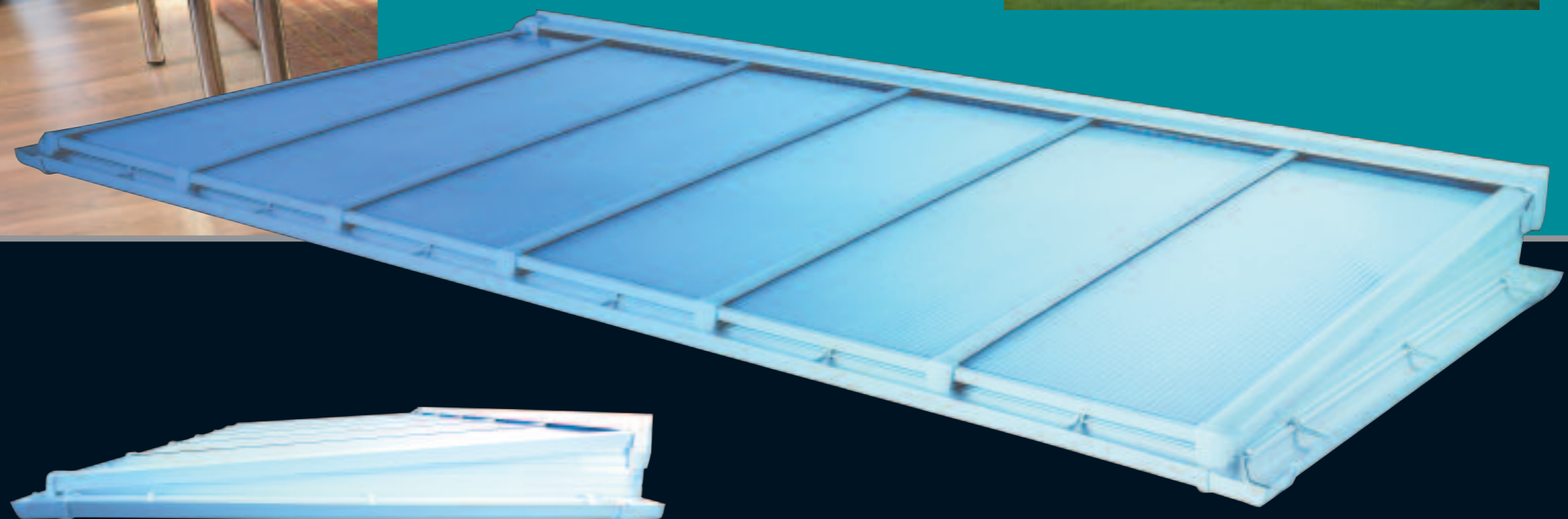



# elevation plus in close-up

- Increased light due to unique one piece hipped wings
- Robust eaves beam all the way round for enhanced structural support, particularly over doors.
- 'Invertabar' glazing bars create cleaner lines and a more aesthetic look both internally and externally
- Only available for installations at a 5° pitch (main slope)
- Thermally efficient design to meet current and anticipated regulations
- Available in White, Deeplas, Light Oak and Rosewood to match existing door and window finishes
- Unique specification polycarbonate in a choice of colours. Available in 25mm and 35mm.
- Suitable for timber, aluminium and PVCu frames (up to 70mm width)

Elevation Plus is a totally unique product that will give you more sales opportunities and a significant advantage over your competition.

The revolutionary new hipped wing design floods the conservatory with light, overcomes the need for firrings or expensive raked frames and creates an open and airy roof area which will sit stylishly with any property.

Elevation Plus can span up to 4800mm (see page 14 for details) making it perfect for both domestic conservatories and commercial applications.

Elevation is designed to work with Ultraframe's unique Conservaflash, ensuring perfect watertight flashing every time.

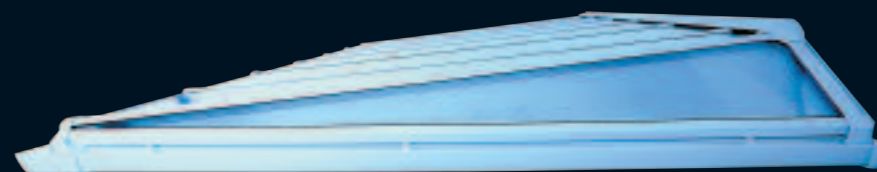
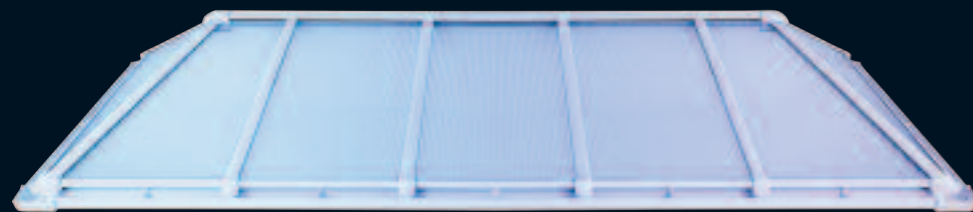
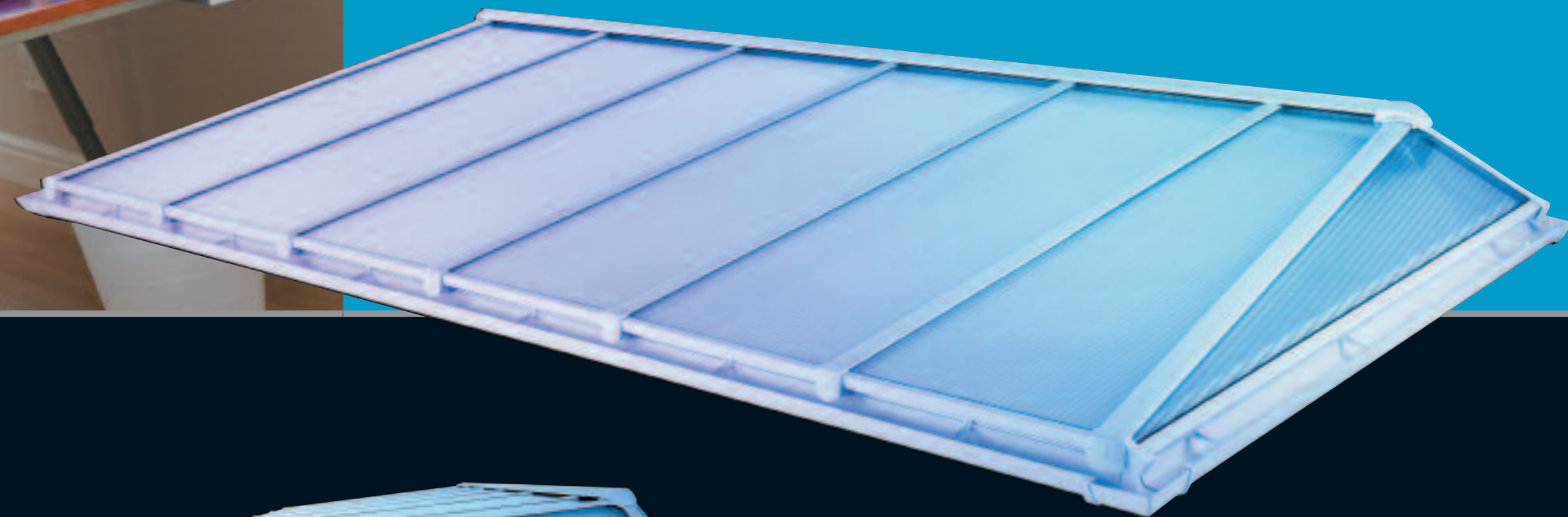

# clicklock technology: the heart of elevation

Unique to Ultraframe is the revolutionary clicklock technology: no bolts to fiddle into place, no holes to drill, no nuts to drop, all the parts are already on the eaves beams and glazing bars. Just offer the two parts up towards each other and push into place. Hear them click and you're ready for the next bar.



clicklock hub and hip bar



hip starter bar



# installation is beautifully simple



With its unique features and innovative solutions, trials prove that Elevation is the fastest and most fitter friendly system you can install. In fact, with fewer parts to carry up and down ladders, many installations can be undertaken by one person.

Here's what some installers had to say;

**'Elevation is quite simply the best product on the market.'**

Mark Dyson,  
Managing Director, Redditch Doors and Windows

**'Our fitters said it was the best roof they've ever fitted and it only took them 40 minutes to do'**

Gareth Short - JH Leeke & Sons



Glazing bars just click into place



## ULTRAFAC

Elevation comes in sequenced and numbered boxes (plus polycarbonate and firrings) to make fitting easier and quicker

# leading the way

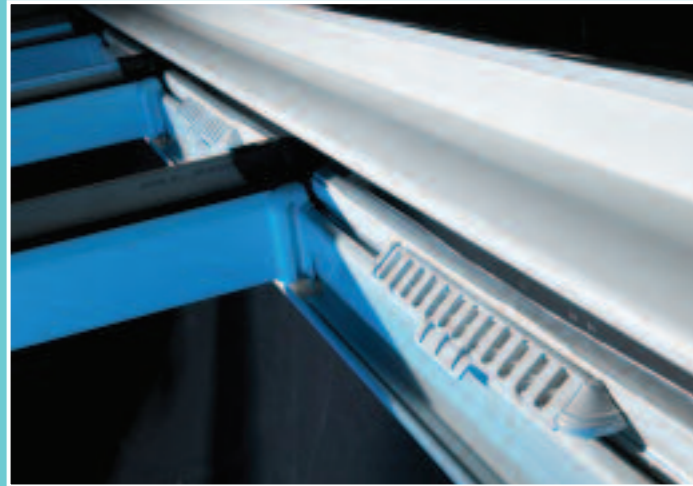

Eavesflow controllable ventilators at eaves and wallplate are standard

There are those who follow and those who set trends and lead. At Ultraframe, we are listening to the market and influencing the bodies that set future industry regulations. This ensures that we develop products to cater for the future .

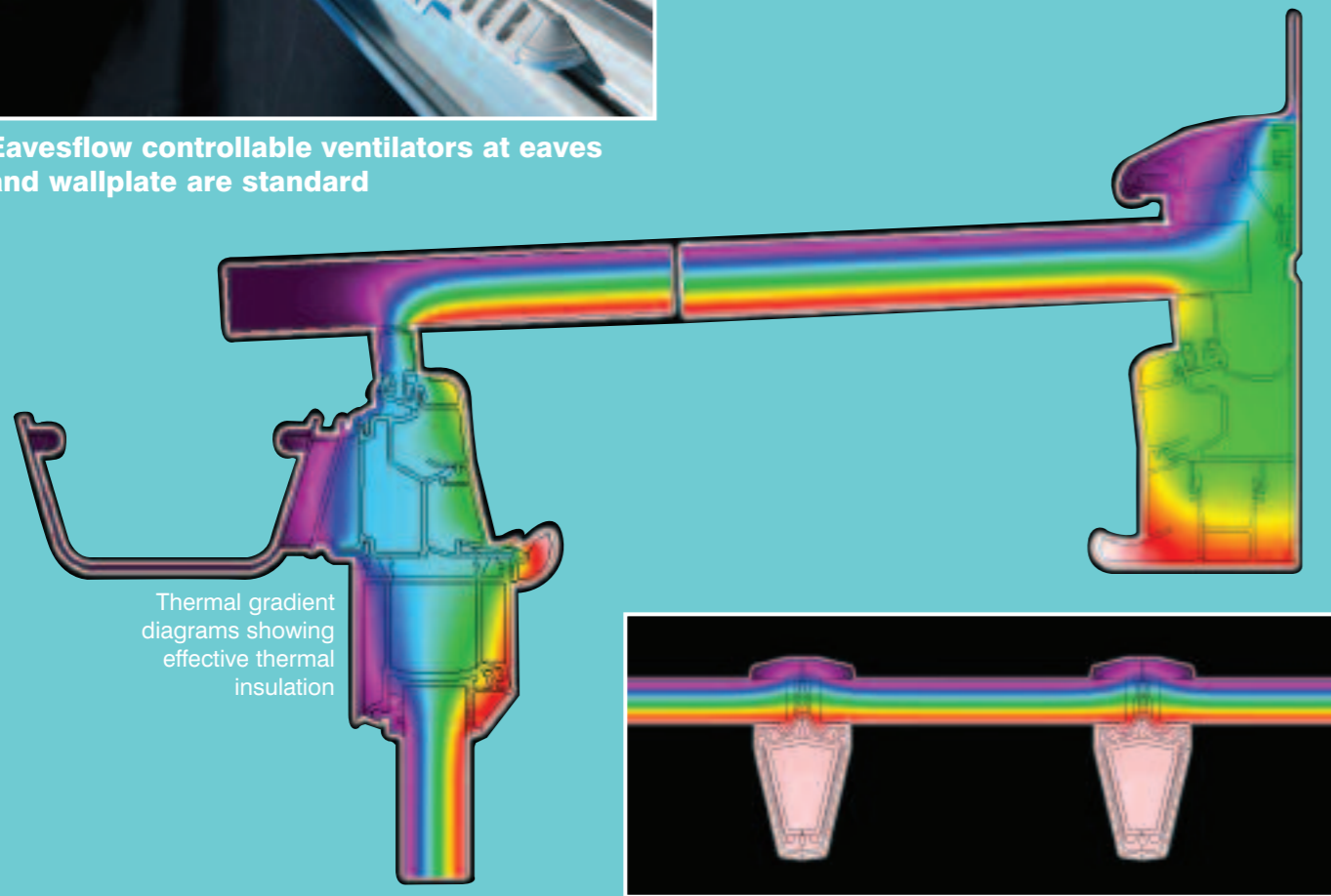

Thermal gradient diagrams showing effective thermal insulation

# system overview

- Uses Clicklock technology for speed and surety of installation
- The 'Invertabar' glazing bar reverses traditional proportions. With its chamfered sides (reinforced as necessary) it maximises light entering the conservatory
- Pre-engineered for Conservaflash™ with soaker integrated into the hip starter bar and with saddle flashing at the hip radius end
- The highest level of pre-fabrication means fewer parts to install on site, minimising errors during installation for 'zero defect' performance

The system consists of three key elements:

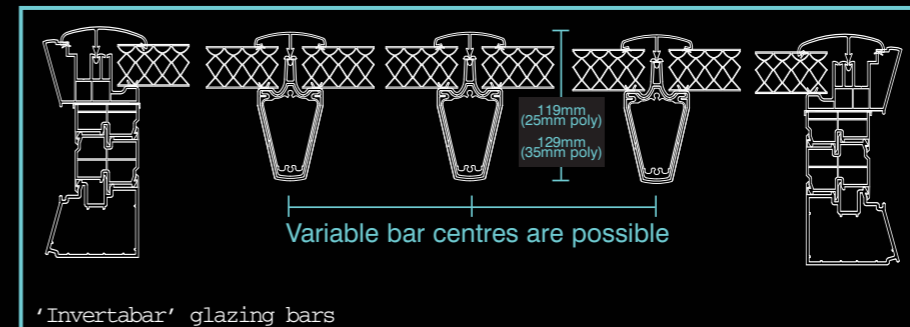

'Invertabar' glazing bars

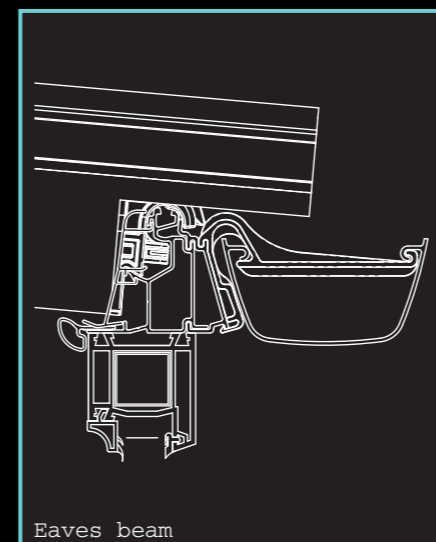

Eaves beam

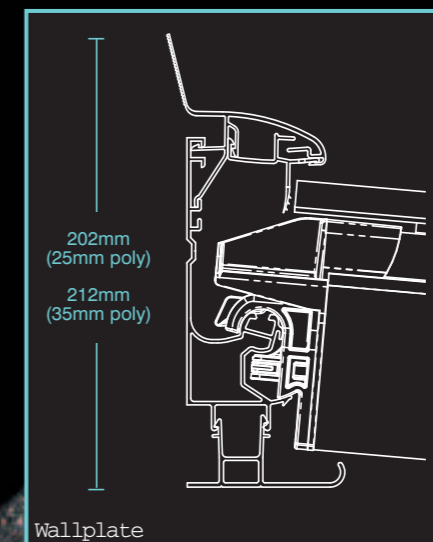

Wallplate

## ULTRAFAC

Elevation offers you the most thermally efficient roof system on the market today, in fact our 25mm system out-performs competitor 35mm systems.

# firring specification data

Ultraframe has taken firring design and performance to a new level with Elevation.

- Available at 2½° and 5° pitch in 3045mm and 4045mm lengths.
- The firrings consist of a series of inter connected/locking profiles that are supplied pre-fabricated.
- Firrings are supplied in 3 different 'conditions' to suit various projections and applications (see table opposite)
- When specifying only one firring, it must be confirmed whether this is the left or right hand (as viewed externally from front of conservatory).

- The guttering can be clipped to the firring allowing the guttering to run along the front and sides of the conservatory. This can save the need for a soakaway as the guttering can be routed back to the house and rain water dispersed down the dwelling's existing fall pipes.

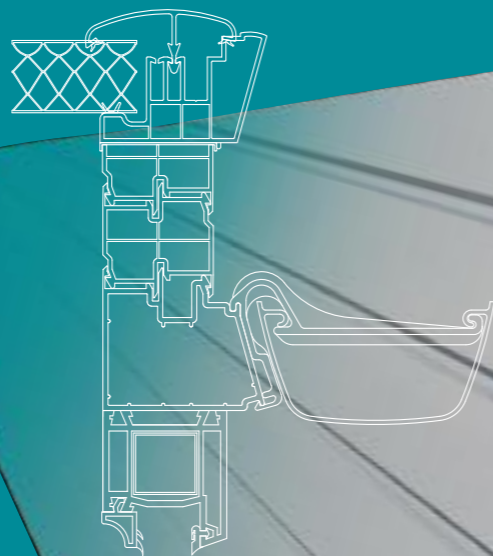

## Alternatives to firrings

In some situations, you or your customer may prefer to either use raked window frames or timber firrings. Basic set out data is detailed on page 21.

Elevation Plus also provides an ideal alternative to firrings, through the use of a hipped wing (see below).

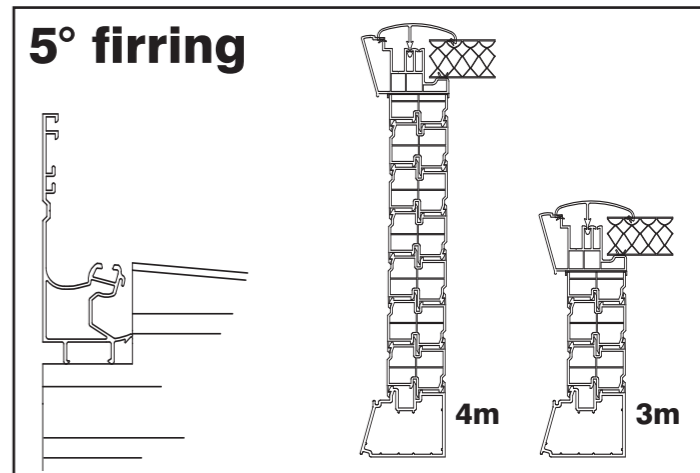
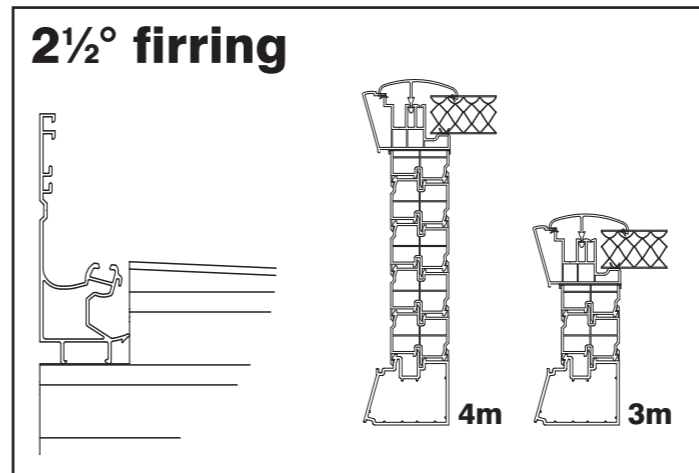
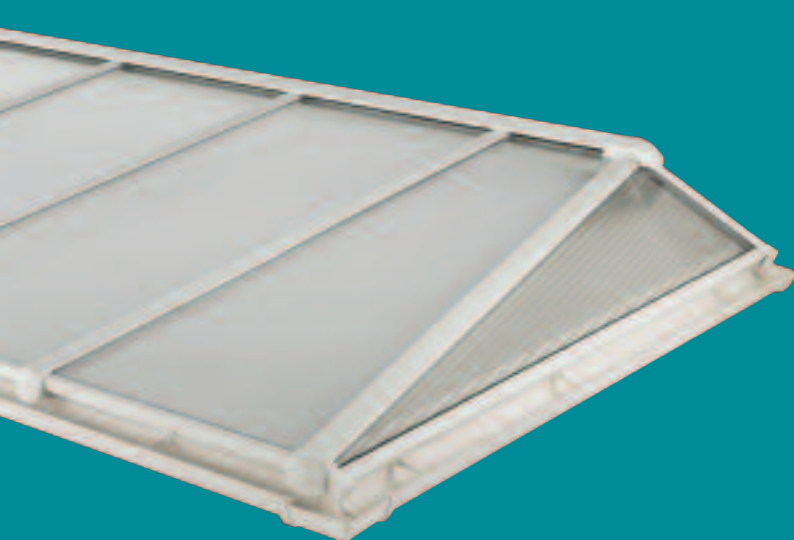

Firring requires notching at the wallplate. Position template provided with the firring.

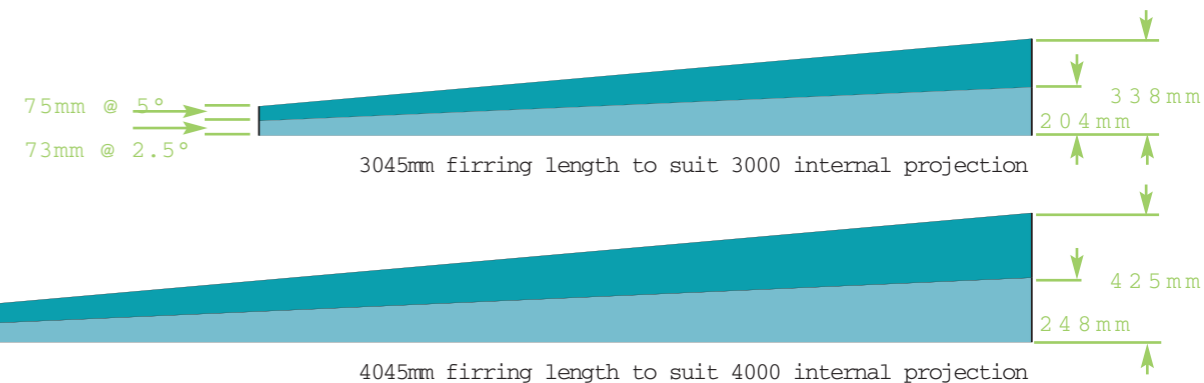

## Recommended firring specification rules:

Ultraframe was the first company to introduce pre-engineered 'cut to falls' firrings. Now, they have gone one step further with these ready assembled interlocking profiles that not only fill the 'hole' between the side frames and the roof but which add substantial support to the whole structure particularly when doors are in the end elevations.

25 or 35 mm Polycarbonate	Standard	Stage 1 Reinforcement	Stage 2 Reinforcement
up to 3m projection			
without doors	●	○	○
with doors	x	●	○
	x	●	○
	x	x	●

● Recommended    ○ Optional    x Not suitable

Stage 1 reinforcement - Aluminium box section, slid into lower profile  
**Note: if you prefer to fix down, stage 1 must be specified**  
 Stage 2 reinforcement - Aluminium box section with 2 galvanised steel structural inserts, aluminium box section

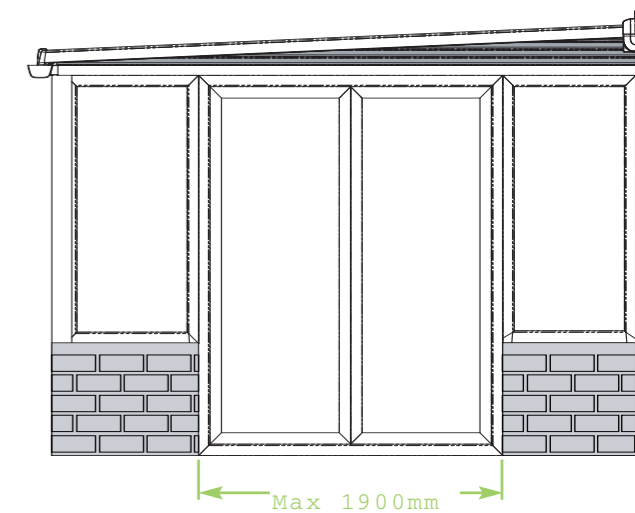

When doors are in either the sides or the front of the conservatory, the door outerframe profile must

## ULTRAFACT

Firring is always supplied sized to suit 3 and 4 metre internal projections lengths, allowing you to cut and configure to suit site conditions.

# technical data

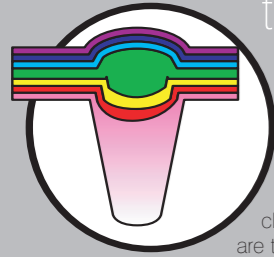

## thermal insulation

Within the foreseeable future it is anticipated that the Building Regulations will re-apply to all conservatories. This will include a 'U' value target for the roof and glazing.

The Ultraframe family of products using clicklock technology and Elevation in particular, are the most thermally efficient roofs on the market today. With thermal sleeving they offer the ultimate in comfort, minimising heat leakage, condensation and cold spots in the conservatory.



## fire performance

The polycarbonate panels have achieved a class 1 rating when tested to BS476-7 : 1987. The spread of flame across the pvc cappings and claddings is limited and in a fire will tend to char and fall away.



## roof access

When accessing the roof for maintenance purposes, timber crawling boards must span across the glazing bars to support the person safely.

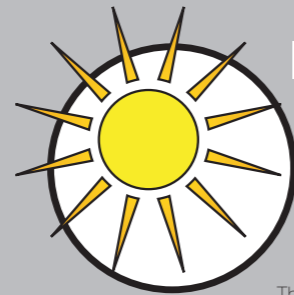

## light transmission

Glazing bar centres of up to 1000 mm and with a one piece hip on Elevation Plus, give maximum light. Specify one of the five colours of polycarbonate to ensure heat build up and glare can be minimised at the same time as light is maximised.

The table opposite gives the % light transmission for each polycarbonate colour and thickness.

Projection Internal Frame (mm)	Internal Frame to centre line of first bar A - B		Bar centres for remaining bars B - C	
	Min (mm)	Max (mm)	Min (mm)	Max (mm)
2500	479	1000	500	1000
2750	519	1000	500	1000
3000	560	1000	500	1000
3250	600	1000	500	1000
3500	640	1000	500	1000
3750	681	1000	500	1000
4000	721	1000	500	1000
4250	761	1000	500	844
4500*	801	1000	500	695
4800*	850	1000	500	528

Max projection of hip with equal bar centres is 4350, bar centres at

\* Aesthetic consideration: at these projections the bar centres across the roof are unequal and unlikely to line through with window mullions below.

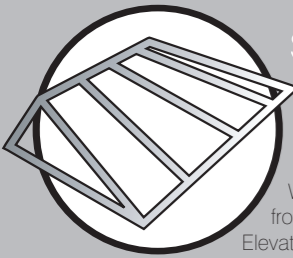

## structural integrity

As a national manufacturer, Elevation will be used anywhere in the country. It has been engineered for the extremes of the UK climate including wind uplift and snow loads. When you order a roof, be it a 'roof in a box' from a national distributor or a fully bespoke Elevation Plus, you can rest assured that the glazing bars are pre-reinforced where necessary. Ultraframe's roof system has been designed to the latest wind code BS6399-2 and certified by the BBA who have given it at least a '25 year' life.

Maximum projection (internal frame) - Standard roof (750/1000mm panel combinations) 4000mm, Bespoke roof (500mm bar centres) 4800mm and Elevation Plus (see below).

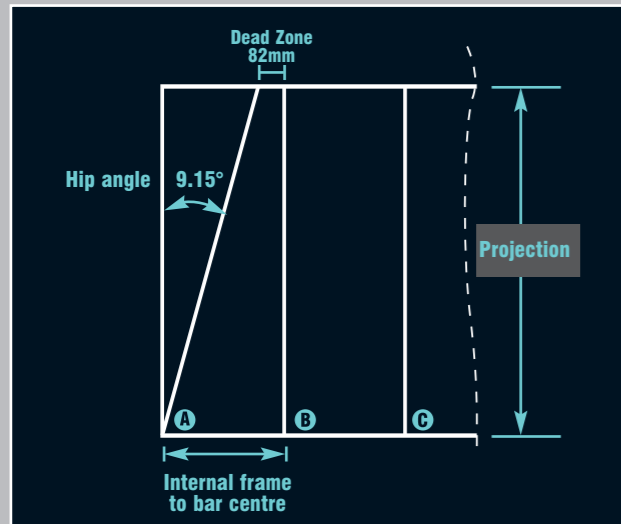

	TECHNICAL DATA	
	25mm Panel	35mm Panel
Glazing centres (mm) - Elevation - Bespoke - Elevation Plus	750/1000 Variable 500-1000 see table across	750/1000 Variable 500-1000 see table across
Maximum Unsupported Projection (mm) - Elevation - Bespoke - Elevation Plus	4000 4800 see table across	4000 4800 see table across
Overall system depth (mm) (cross section of bar)	119 mm	129 mm
'U' value - (Wm <sup>2</sup> k <sup>-1</sup> ) - Polycarbonate - Typical roof (4m x 4m)	1.5 or 1.7 1.6 or 1.8	1.5 1.6
Weight kg/m <sup>2</sup>	6	7
Airbourne Sound Reduction (dB)	23	25
Pitch (°) - modular or bespoke roof - Elevation Plus - Main roof - hipped wing	2½ - 10 5° 28½°	2½ - 10 5° 28½°
Glazing colours + light transmittance (%)	Clear 65% Opal 15% Bronze 25% Bronze/opal 10% Solar control 5% -	Clear 63% Opal 15% Bronze 20% Bronze/opal 10% Solar control 5%
Controllable trickle ventilation	Standard at eaves and wall plate (Eavesflow)	
System colour	White, Deeplas, Rosewood or Light Oak	
Structural firrings	2½° or 5°	2½° or 5°
In line roof vent between bars	Yes	Yes

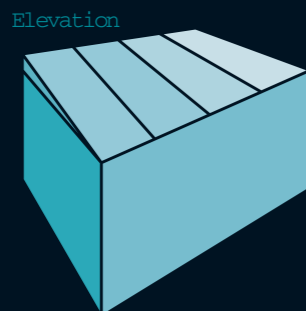
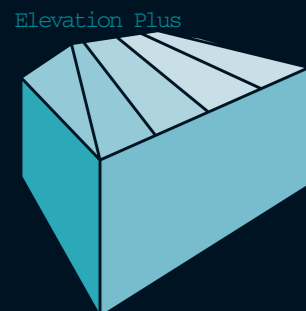

## POLYCARBONATE ROOFS - PROJECTION Vs BAR CENTRES

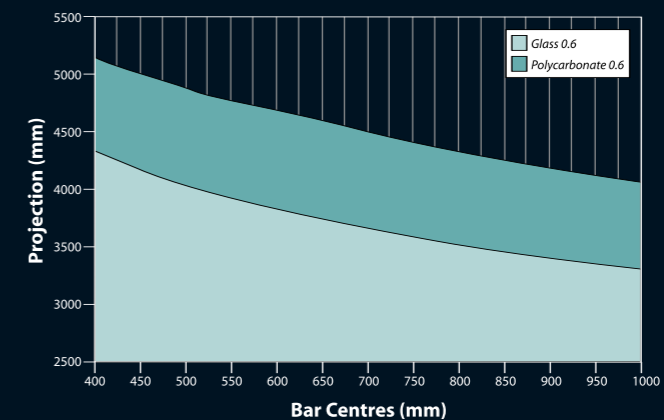



# Set out details

Elevation can be ordered as a standard 'modular' roof - use this guide, design your frames and base to fit the modular sizes. Alternatively, simply cut to size on site or you could allow Ultraframe to 'bespoke' it for you.

Whatever you decide to do, the tables below are the starting point for the design and ordering of your Elevation roof.

## elevation width (w) information

'Roof in a box*' pack width (mm)								
2000	2500	3000	3500	4000	4500	5000	5500	6000
Nominal panel widths* and numbers in pack								
1000 x 2	750 x 2 1000 x 1	1000 x 3	750 x 2 1000 x 2	1000 x 4	750 x 2 1000 x 3	1000 x 5	750 x 2 1000 x 4	1000 x 6
Internal Frame Width (mm)								
1945	2445	2945	3445	3945	4445	4945	5445	5945

\* N.B Panels are actually 730 mm (750 centres) and 980 (1000 centres) wide

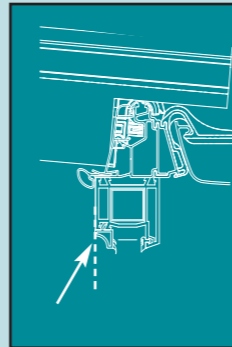

## elevation projection (p) information

'Roof in a box' Pack projections	Internal Frame for 2 1/2° and 5° pitch	
	2 1/2°	5°
2000	2000mm	1994mm
2500	2500mm	2493mm
3000	3000mm	2991mm
3500	3500mm	3490mm
4000	4000mm	3989mm
over 4000mm projection at modular bar centres a goalpost/purlin is required to provide additional support. A projection of 4800mm is possible at 500mm centres without support		
5000	5000mm	4986mm
6000	5815mm	5799mm

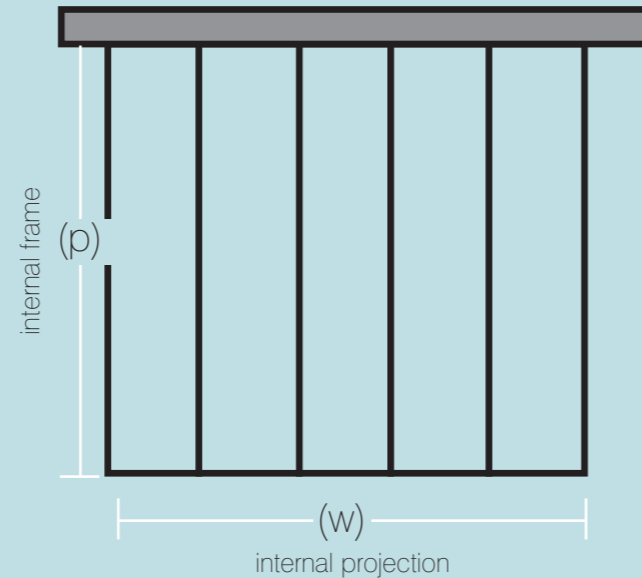

## ULTRAFACT

All width and projection dimensions on Elevation are internal frame.

When buying your 'Roof in a box' in a standard size, it is important to check that it will fit your frames, which you may have pre-designed/pre-ordered. This is particularly important if you are moving away from a 2 1/2° pitch, which is the

'datum' for set out information. Use the 'look up' table below to check the internal projections at various pitches eg. a 3000mm 'Roof in a box' will suit an internal projection of 2991mm at 5° and 2957mm at 10°

## Internal projections based on 'Roof in a box' at 2 1/2 - 10 degree pitch

'Roof in a box' pack projections	Pitch in degrees														
	2.5	3	3.5	4	4.5	5	5.5	6	6.5	7	7.5	8	8.5	9	9.5
2000	1999	1998	1997	1996	1994	1993	1991	1989	1987	1985	1982	1980	1977	1974	1971
2500	2499	2498	2496	2495	2493	2491	2489	2486	2484	2481	2478	2475	2472	2468	2464
3000	2999	2997	2996	2994	2991	2989	2986	2984	2980	2977	2974	2970	2966	2962	2957
3500	3499	3497	3495	3493	3490	3487	3484	3481	3477	3473	3469	3465	3460	3455	3450
4000	3998	3996	3994	3991	3989	3985	3982	3978	3974	3970	3965	3960	3955	3949	3943
4500	4498	4496	4493	4490	4487	4484	4480	4475	4471	4466	4460	4455	4449	4443	4436
5000	4998	4995	4993	4989	4986	4982	4977	4973	4967	4962	4956	4950	4943	4936	4929
5815	5813	5810	5807	5803	5799	5794	5789	5783	5777	5771	5764	5757	5749	5741	5732



To calculate the overall height of your conservatory, for example when the possibility exists that the roof may foul an obstruction

overhead like a waste pipe or bungalow eaves, use the table below along with the additions listed underneath the table.

## Height from top of window frames to top edge of aluminium wallplate

Pitch in degrees	Projection (mm)															
	2500	2600	2700	2800	2900	3000	3100	3200	3300	3400	3500	3600	3700	3800	3900	4000
2.5	262	266	271	275	279	284	288	292	297	301	305	310	314	319	323	327
3.0	284	289	294	299	305	310	315	320	326	331	336	341	347	352	357	362
3.5	306	312	318	324	330	336	342	349	355	361	367	373	379	385	391	397
4.0	328	335	342	349	356	363	370	377	384	391	398	405	412	419	426	433
4.5	350	358	365	373	381	389	397	405	413	421	428	436	444	452	460	468
5.0	372	380	389	398	407	415	424	433	442	450	459	468	477	485	494	503
5.5	394	403	413	423	432	442	452	461	471	480	490	500	509	519	529	538
6.0	416	426	437	447	458	468	479	490	500	511	521	532	542	553	563	574
6.5	438	449	461	472	484	495	506	518	529	541	552	563	575	586	598	609
7.0	460	473	485	497	509	522	534	546	559	571	583	595	608	620	632	644
7.5	483	496	509	522	535	548	562	575	588	601	614	627	641	654	667	680
8.0	505	519	533	547	561	575	589	603	617	631	645	659	673	688	702	716
8.5	527	542	557	572	587	602	617	632	647	662	677	692	707	721	736	751
9.0	550	565	581	597	613	629	645	660	676	692	708	724	740	755	771	787
9.5	572	589	606	622	639	656	672	689	706	723	739	756	773	790	806	823
10.0	595	612	630	648	665	683	700	718	736	753	771	789	806	824	841	859

### Additions to table values

Distance from top of Wallplate to top of Wallplate Capping for 25mm poly= 38mm  
 Distance from top of Wallplate to top of Wallplate Capping for 35mm poly= 48mm  
 Distance from underside of Wallplate to top of Aluminium Wallplate = 125mm  
 Distance from top of Wallplate to bottom of undercladding = 164mm

Simplified formula: Height from top of window frames to top of Aluminium wallplate  
 (Proj + 9mm) \* tan (pitch) + 152

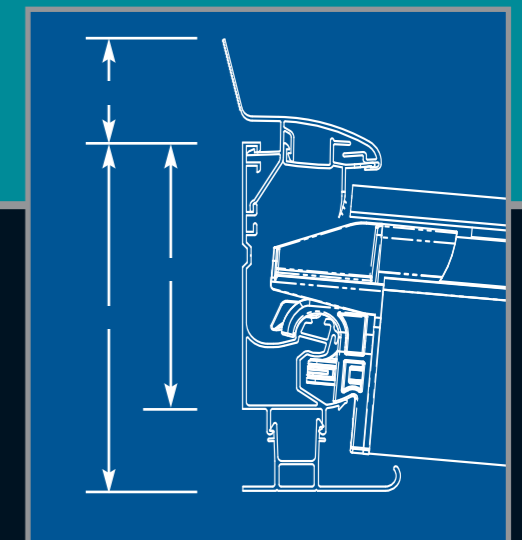

# elevation bespoke options

Elevation comes with a myriad of additional design solutions. Whether you are building tight against an existing masonry abutment, or you need the assurance of additional support,

with a goal post arrangement or a box gutter to assist when a bungalow's eaves is too high, Elevation in its bespoke form provides an effective solution to all of these issues.

## Bespoke 'Made to Measure' Service

Designing your conservatory base and frames to fit one of the 'Roof in a box' sizes is the simplest and easiest way to effective conservatory sales. If this is not possible, Elevation can be configured on site in no time at all. The installation guide provided with the roof has all the details.

However, if time is not too pressing, why not let Ultraframe take the strain and factory configure your roof to the nearest millimetre. Furthermore, you have the option of changing the bar centres too, giving you the further option of lining roof glazing bars through with frame mullions.

## Conservaflash™

Ultraframe Conservaflash™ consists of a box of 570mm straight pre-engineered flashings that replace old fashioned lead.

Allowing for overlaps each 570mm section has an effective length of 500mm and provides a quick and consistent weatherproof finish.



They can be ordered in 2m, 3m and 4m packs of straight flashings

On Elevation Plus, the 28.5° starter bar on the one piece hipped wing features an integral soaker, whilst stepped flashings (featuring weatherbars to prevent windblown rain penetrating behind them) are progressively fitted towards the hip bar/wallplate hub which features an integral flashing trim/saddle.

When the side of the conservatory abuts an adjacent masonry wall, Conservaflash can be specified for this too.

By using Ultraframe Conservaflash, you will speed up installation and have peace of mind since all parts are pre-engineered and have the backing of BBA Certification.

You have the option to use the standard parts supplied (using the guidance notes in the installation guide) or opt for the factory configured starterbar and cloaking trim/conservaflash.

## Elevation Boxgutter

On 2.1m frames at 2½° pitch with 3m internal projection and 25mm poly, Elevation is only 2422mm high where the wallplate top cap joins the existing house.

Despite this, there are just some situations that demand something extra. That's where the Elevation boxgutter comes in.

It allows the conservatory roof to effectively stand higher than the adjacent house roof whilst at the same time taking drainage from the existing dwelling. It can be specified with boxgutter adapters too.

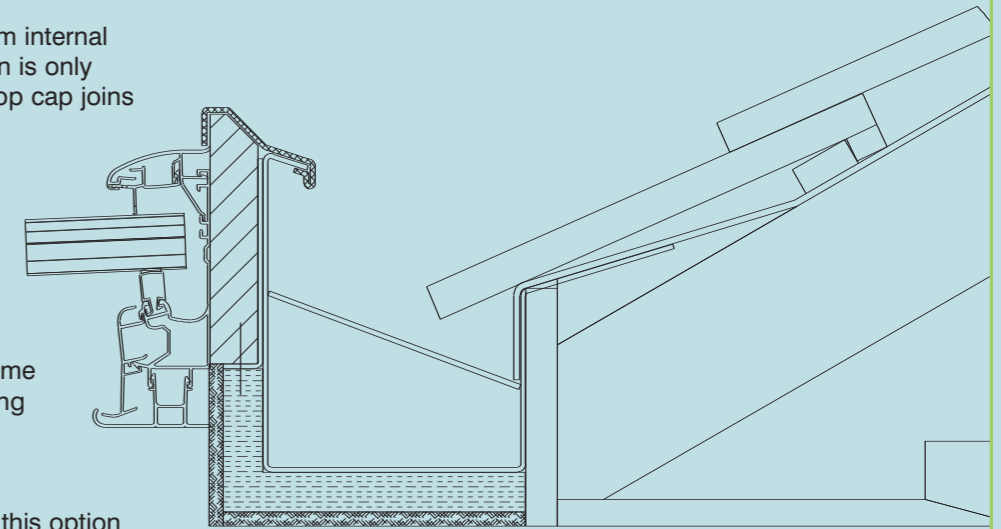

For more information on specifying this option please request the boxgutter order form.

## Additional Support For Non-Standard Projections

The spanning performance of Elevation is quite exceptional. However, in some situations you may need to go that bit further.

That's why Ultraframe can offer a goal post arrangement that supports the roof at the midpoint in its span and then, through two structural 'legs', transfers the loads down into the base through a holding down plate.

These goalposts and purlin arrangements are manufactured in-house at Ultraframe from powder coated structural grade aluminium. Please ask for further details.

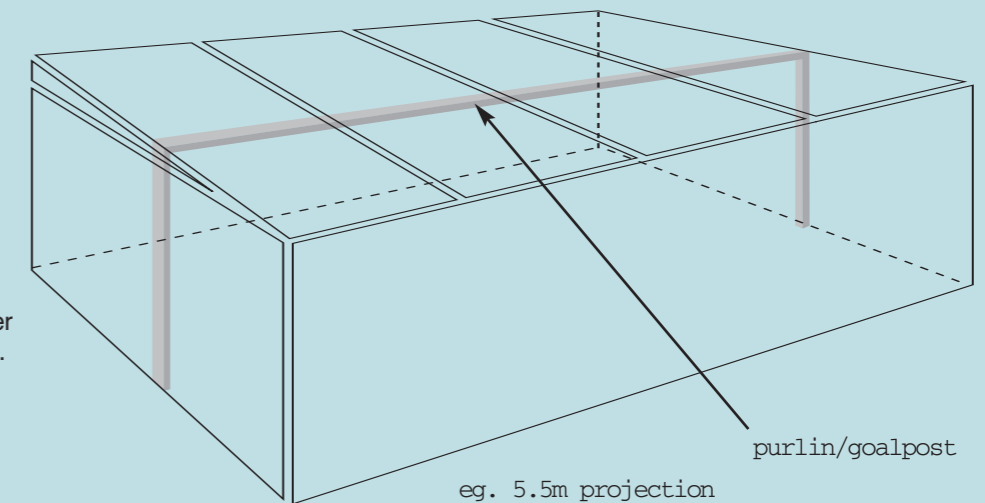

## ULTRAFAC

Elevation can be fully installed without climbing on to the roof at any stage.

## Masonry Abutments

A number of situations occur on site where a conservatory may need to be built alongside/adjacent to a masonry obstruction. This may extend beyond the front of the conservatory or finish half way along the side of the roof.

Ultraframe offers a number of solutions for these awkward details.

In the example below right the abutment bar will need to be flashed in lead. Combine this with the optional Conservaflash for other details and you have the perfect weatherproof detail.

Conservaflash 90° external and internal corners have been developed to complete the BBA approved flashing system. The 90° internal corner works in conjunction with the conservaflash handed saddle flashing.

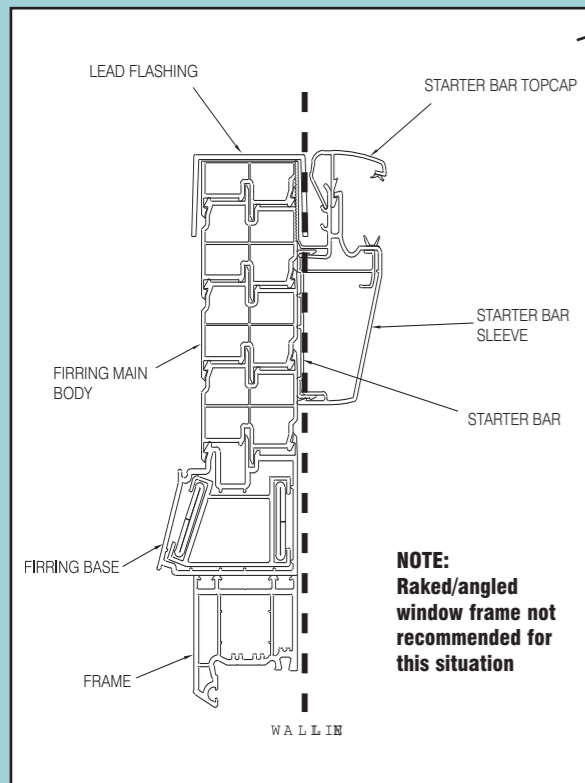
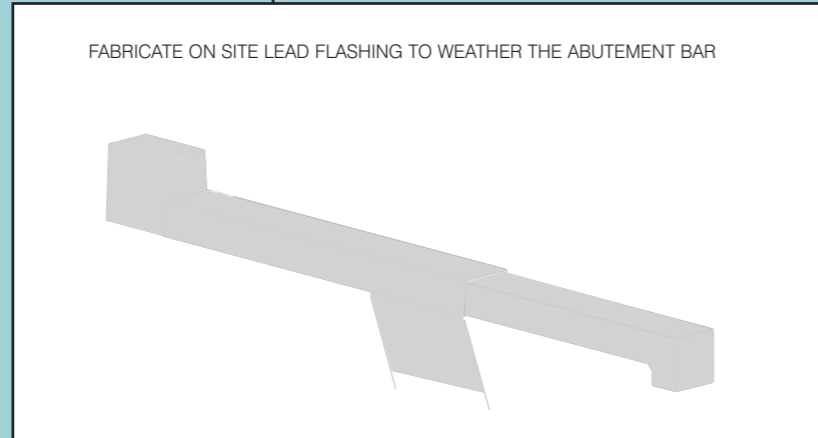
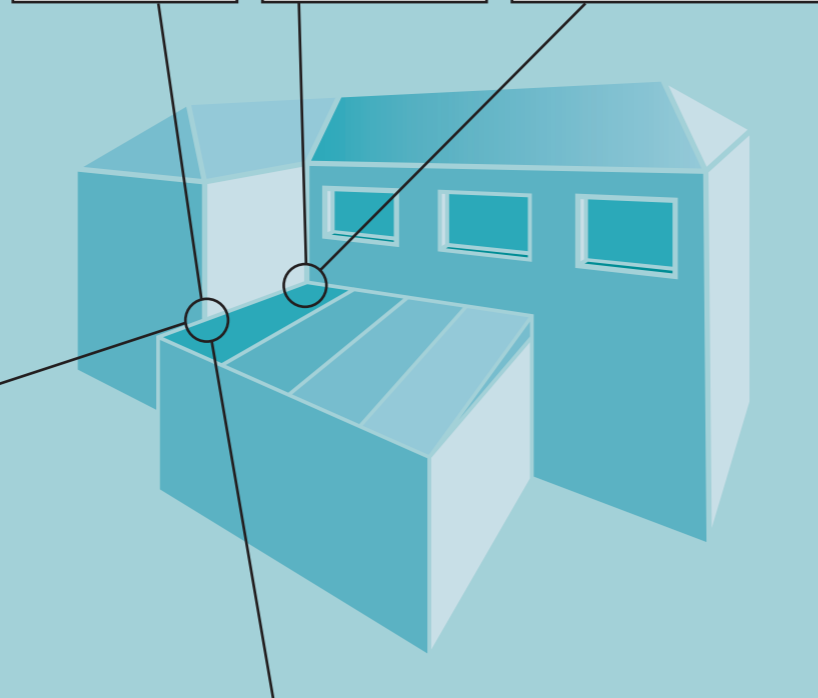
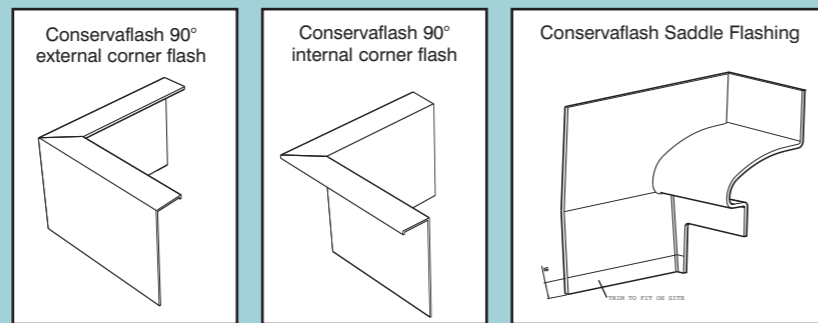

## Timber firrings and raked frames

Elevation has optional structural firrings at 2½° and 5° to cater for the most popular onsite demands. However, occasionally a timber furring may be required and below are brief specification details for it.

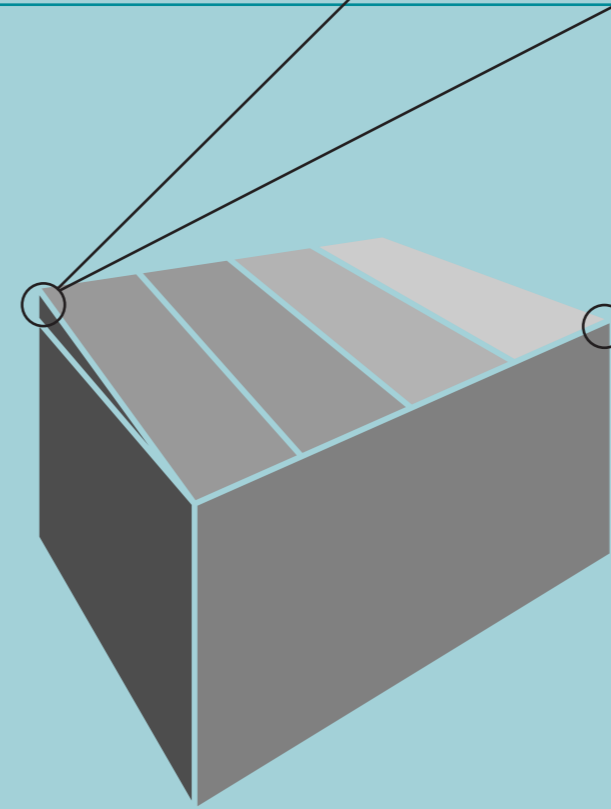
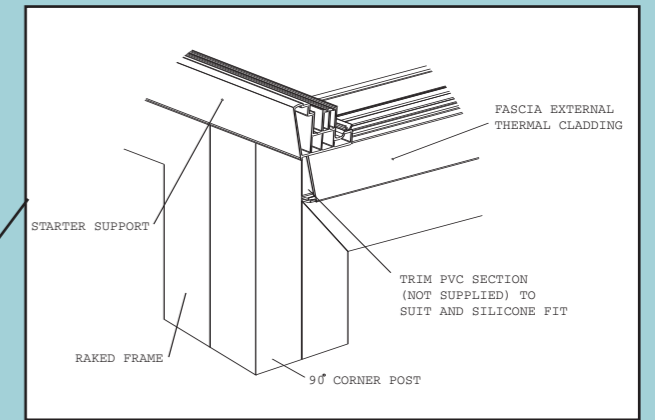
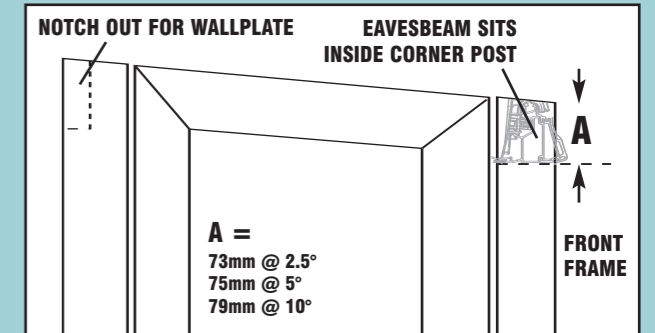
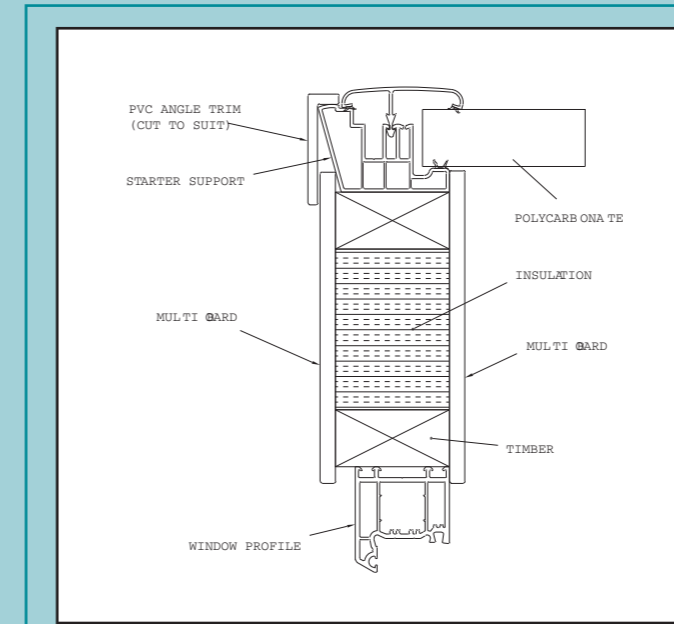

On steeper pitches, typically 10°, a raked glazed frame may be the preferred option. In these instances we recommend the use of a corner post. Where the frames butt up to the house wall; this will require notching to seat the elevation wallplate on. At the front elevation, the raked frame sits behind the corner post.

For help and advice on raked frame design please contact the Technical Support team at Ultraframe:

Tel. 0870 414 1008  
Fax. 0870 414 1018  
email. [techsupport@ultraframe.co.uk](mailto:techsupport@ultraframe.co.uk)

## ULTRAFAC

On-site configuration of bars is made easy with only square cuts required

## Fascia fixing system

The Elevation wallplate has been redesigned to enable the product to be installed in situations where there is restricted space available under the eaves, for instance on a bungalow project.

The new wallplate includes a "witness line" to give guidance for cutting it into two separate pieces. The upper section of the wallplate can then be brought forward to fix to the front of the fascia, whilst the glazing bars can be fitted as normal to the lower section of the wallplate and the top capping fitted onto the upper section, to weatherproof the detail.

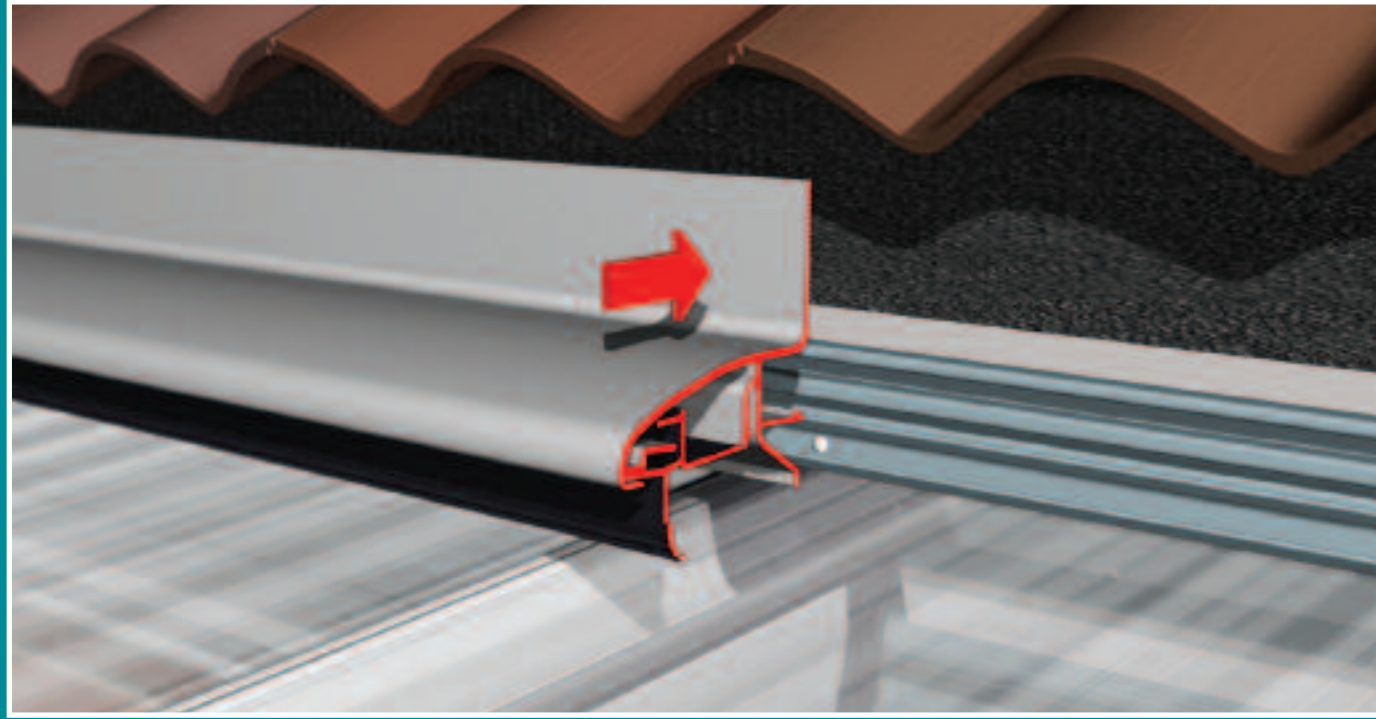

## Installation Guides

These next generation installation guides use photo realistic images to make installation even easier. Every possible permutation is covered and we strongly recommend reading the guide prior to fitting.

Other features of the Installation Guides include:

- Component identification chart to make ordering damaged/replacement items easier
- Clear and concise guidance on how to site trim a modular roof
- Detailed advice on how to install against wall abutments



# a wide choice of roof shapes

Elevation allows you to build lean-to conservatories to a wide variety of property configurations. Whether the house elevation is a blank canvas or has awkward details like existing extensions alongside, with Elevation you have the maximum opportunity.

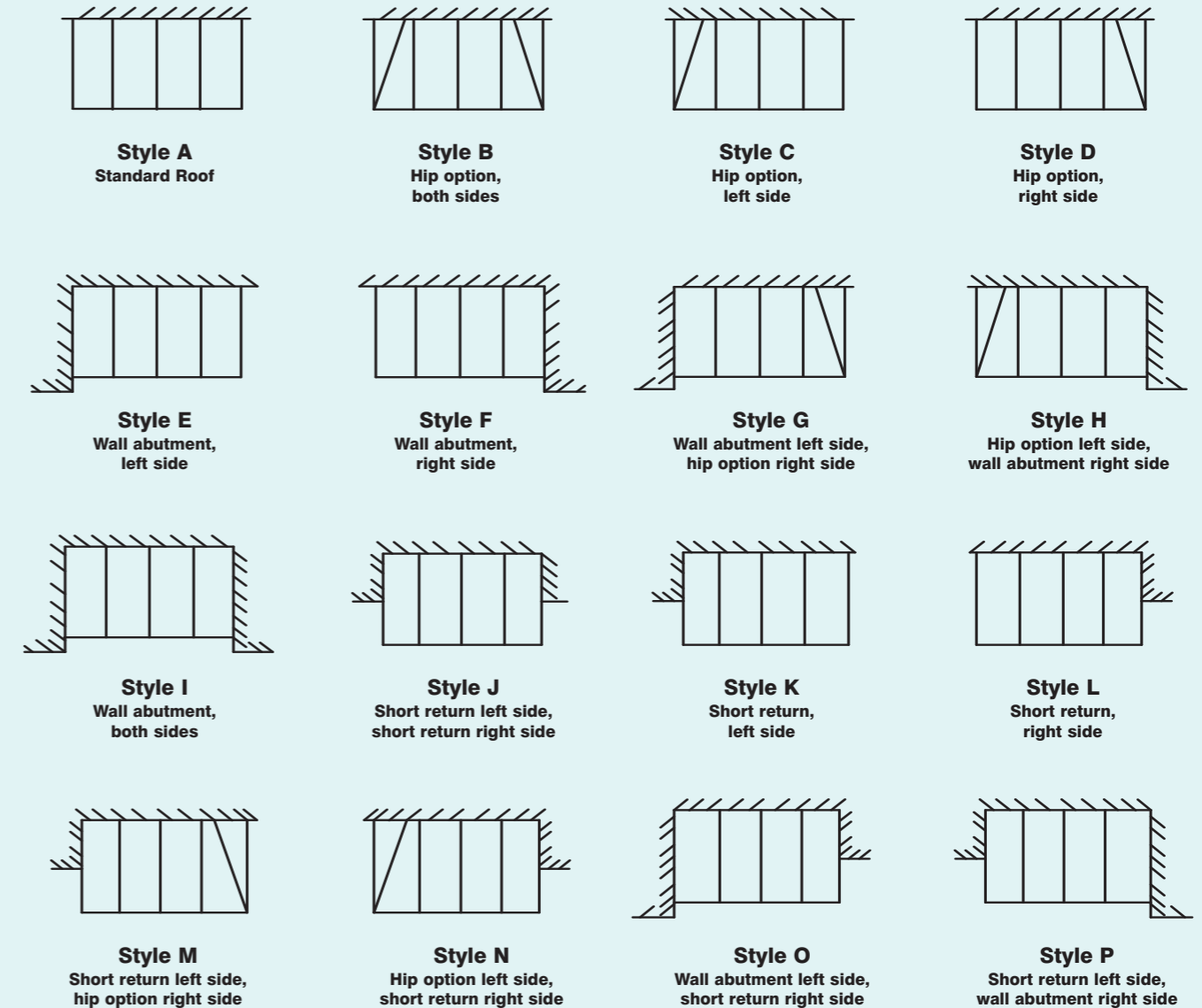

Detail below applies to Styles J, K, L, M, N, O & P

